

# MOBISPA 60

the mobile



**SPANOS**  
BUILDING ON TRUST

# MOBISPA 60

The Mobispa-60 manufactured by SPANOS Industries is an integrated mobile concrete batching plant. The systematic observation of modern construction needs led to the design of a flexible, safe and cost-efficient plant, with guaranteed quality backed by highly-acclaimed certifications.

## Minimised Plant Relocation Cost

Mounted on a two-axle semitrailer, it can be transported from one jobsite to the next by means of an ordinary two-axle tractor.

## Easy Transport

Fully compliant with the European traffic code and EU Directives. This means that no special license is needed for its circulation in all the countries of the European Union.

## Quick and Easy Installation

Can be fully deployed within just a few hours from arriving on site, with no need for special infrastructure or a specialized crew. The Mobispa-60 is fitted with all necessary systems, fully assembled and connected for operation: storage, control, weighing, transport and mixing systems as well as anything else that may be required are fully integrated into the plant, thus making it entirely autonomous.

## Stability and Safety

Its specifications thoroughly comply with DIN 15018 HZ requirements as set by TÜV Germany. Construction quality is certified to ISO 9001:2008, with manufacturing materials supplied by recognised international firms. The Mobispa-60 is fitted with flexible cables rated for external installations and insulation made of high-resilience elastic, along with CE certification.



**The only mobile concrete batching plant in the world with European homologation as a semi-trailer vehicle.**



### **Production of High Standard, Ready-mixed Concrete**

#### **Fast cycle times**

The Mobispa-60 produces a certified yield of 55 m<sup>3</sup>/hour according to DIN 1045 specifications.

#### **State-of-the-art Automation**

The automation system has been custom-designed for automatic management and control of the plant, rendering it compact, functional and efficient. The system is capable to provide printouts which can certify the final product's composition.

#### **Reliability, After-sales Service**

The Mobispa-60 is accompanied by comprehensive manuals covering installation, usage and maintenance in localized language, with thorough training of users also available. The company has a detailed code-numbered catalogue of spare parts and offers 24h/7d technical support, with guaranteed delivery of spare parts within 24 hours.

#### **Registered Patent**

The Mobispa-60 is a SPANOS Industries patented design, registered with the **Hellenic Industrial Property Organisation** ("OBI", patent reg. no. 1006037). Its production is a fully standardized and industrialized process developed by SPANOS Industries, one of the leading companies in its field, with ongoing growth in the manufacture, repair and distribution of construction machinery and equipment in the Balkans and Cyprus and backed by years-long experience and complete technical specialization.





MOBISPA

SPANOS

## Basic Dimensions **mm**

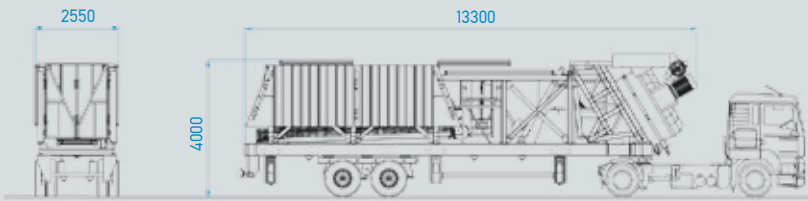

Transport dimensions

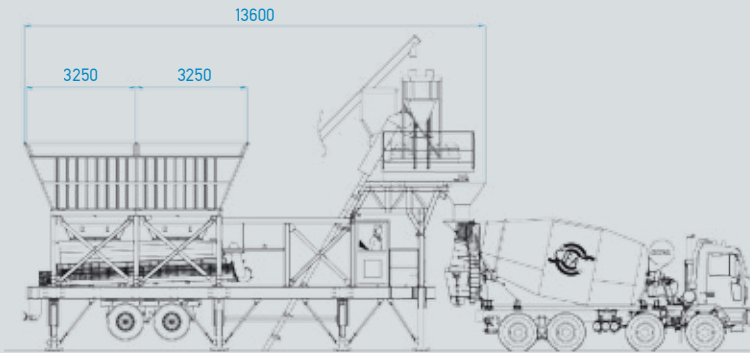

Operating dimensions

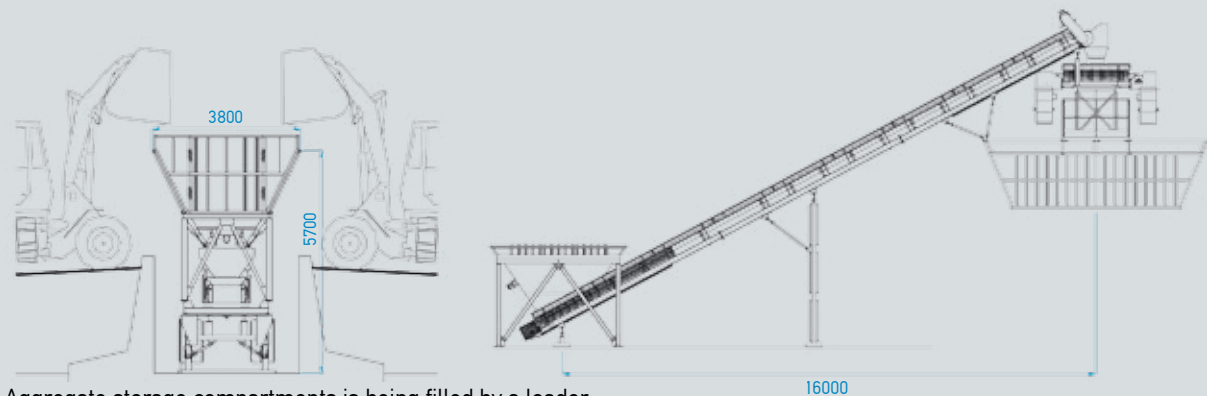

Aggregate storage compartments is being filled by a loader approaching either side of the plant

Optional prefeeding system

## Main Technical Details

Theoretical hourly production	~ 55 m <sup>3</sup> /h Vibrated Concrete compliant to DIN 1045
Aggregate compartments	4 X 7.5 = 30 m <sup>3</sup>
Aggregate weighing unit	~ 4 m <sup>3</sup> - with 4 load cells
Weigh belt	800 X 5800 mm
Loading skip	1.500 m <sup>3</sup>
Mixer	1 m <sup>3</sup> vibrated concrete
Cement screw conveyor	1 X Ø 219 X 6500mm
Cement weighing unit	600 lt - with 3 load cells
Water weighing unit	250 lt - with 3 load cells
Air compressor	300 lt
Automated Electronic Control	Genyx TL(laptop - PLC)
Manual mode	pushbutton on panel
Operator cabin	1 X 1.9 X 2.1 m
Air conditioning	9,000 BTU
Usage & maintenance manual	
CE certificate as per EU directive 98/37	



# SPANOS

BUILDING ON TRUST

## THESSALONIKI - HEAD OFFICES

3rd zone, Square Block 42,  
Industrial Area of Sindos,  
P.O. Box 63, GR 570 22  
Tel: +30 2310 586600  
Fax: +30 2310 586650  
greece@spanos-group.com

## LIMASSOL

208, F. Roosevelt Ave.  
3045 Zakaki - Limassol  
Tel: +357 25 662611 & 12  
Fax: +357 25 827970  
cyprus@spanos-group.com

## BUCHAREST

Drumul Garii Nr 25-35 Otopeni,  
Bucharest  
Tel: +40 021 3524304  
Fax: +40 021 3524303  
romania@spanos-group.com

## SKOPJE

33a/16, Leninova St., P.O. Box 462  
Skopje  
Tel: +389 70 393287  
Fax: +389 34325185  
skopje@spanos-group.com

## TIRANA

Autostrada Tirana - Durres,  
km 7 Kashar, Tirana  
Tel: +355 44 504176  
Fax: +355 44 504177  
albania@spanos-group.com

## PRISHTINË

Magjistralja Prishtinë-Gjilan  
km i 2-te, Veternik-10000 Prishtinë, Kosovo  
Tel: +381 38602194  
Fax: +381 38602193  
kosovo@spanos-group.com

[www.spanos-group.com](http://www.spanos-group.com)



watch us



connect with us



like us



## Installed Power for Standard Version

No.	Description	kW	Startup
1	Mixer	45	YD
2	Skip	9.2	DOL
3	Hydraulic pump	4	DOL
4	Conveyor screw	7.5	DOL
5	Air compressor	3	DOL
6	Water pump	4	DOL
7	Weigh belt	7.5	DOL
8	Cement weigh vibrator	0.25	DOL
9	Aggregate weigh vibrator	0.25	DOL
10	Sand hopper vibrator	0.38	DOL
	TOTAL	81.08	

## Optional equipment

- Printer
- Extra cement screw conveyor, complete  $\Phi 219-6.5m$
- Sand humidity meter
- Set of vibrators for additional sand compartment
- Weighing unit for chemical additives, complete
- Mixer filter
- Steel loading ramp
- Steel base for cement silo
- Sound-insulated, ground-standing Generator Set, 180kVA rating and full 15m cabling
- Silo filter with safety valve
- Silo maximum level indicator with siren and beacon.
- Minimum level indicator with beacon
- Cement silo safe-loading system
- Prefeeding system for aggregate compartments
- Mobile cement silo

The manufacturer reserves the right to modify product characteristics either completely or partially without prior notice.

